

MiniTec B & D Dash Harness Wiring Instructions:

All of the following wires are connected to the car wiring harness.

The following wires are necessary to make your Honda Engine start and run.

CONSTANT (+12V): Connect this wire to a fused Constant +12V source from the car. This wire provides Constant Power to the Honda ECU which enables the ECU to retain error codes necessary to troubleshoot any MIL (Malfunction Indicator Light) occurrences.

SWITCHED +12V: Connect this wire to a fused Switched +12V source from the car. This wire provides Switched Power to the Honda Engine Harness. This is power for the ECU, which causes the ECU to power up. When the ECU powers up it causes the ECU to send power to the Main Relay, which powers up the Fuel Pump +12V. This Wire also provides power to the Engine Sensors and the Fuel Injectors. In addition this wire provides power to the Coil and the Alternator.

GROUND: Connect this wire to chassis ground, this is the reference ground for the ECU as well as being tied to the ground connected to the engine.

FUEL PUMP (+12V): Connect this wire to the Positive terminal of the Electric Fuel Pump. This wire is the Fuel Pump power output from the Main Relay.

START SIGNAL: Connect this wire to the start terminal on the key switch or the momentary Start Pushbutton. By applying +12V to this wire the starter is energized.

The following wires are connected to relays to control the function of their respective devices.

FAN CONTROL: This wire is the ground for the Fan Control Relay. Use the following diagram for the Fan Control Relay.

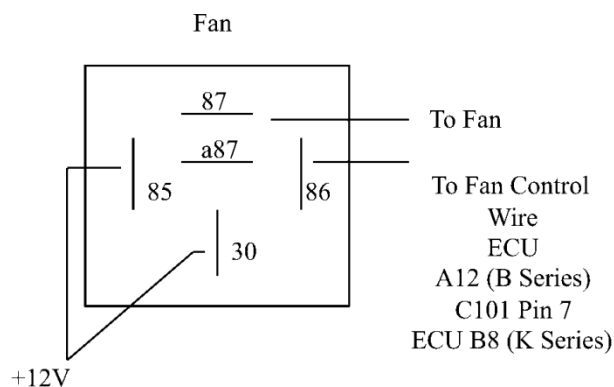

A/C SWITCH: This wire is used to tell the ECU that the Air Conditioner has been turned on. Honda uses ground signals to and from the ECU. Therefore the A/C needs to have this wire grounded in order to turn on the A/C. Use the following diagram to wire the A/C Switch Relay.

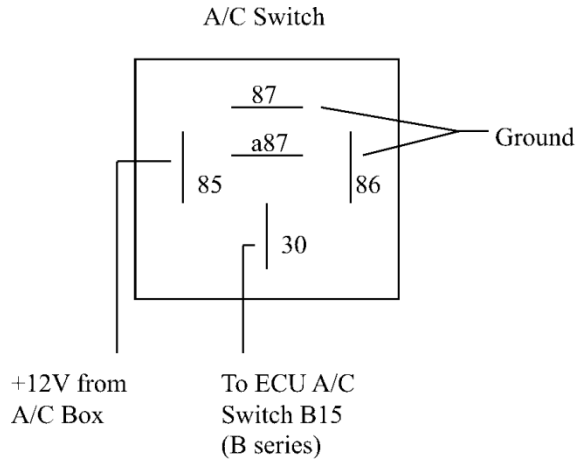

A/C CLUTCH: This wire is the ground for the A/C clutch relay. Use the following diagram to wire the A/C Switch Relay.

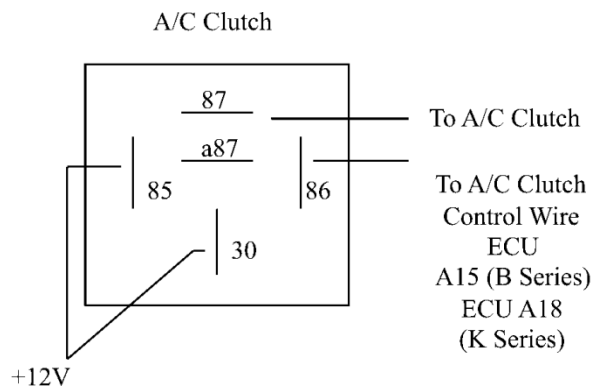

The following wires are connected to gauge and lighting circuits.

FUEL GAUGE: This wire is the signal wire for the Fuel Gauge. Connect this wire to the output from the Fuel Gauge sending unit.

OIL PRESSURE GAUGE: This wire is the signal wire for the Oil Pressure Gauge. Connect this wire to the output from the Oil Pressure gauge sending unit.

INSTRUMENT LIGHTS: This wire powers the instrument light +12V. Connect this wire to the parking light circuit. If using a single position switch connect to the Headlight switch.

HI BEAM INDICATOR: This wire is the power for the Blue High Beam Indicator light in the dash. Connect this wire to the High Beam output from the dimmer switch.

RIGHT TURN INDICATOR: This wire is the power for the Green Right Turn Indicator light in the dash. Connect this wire to the Right Turn Signal circuit.

LEFT TURN INDICATOR: This wire is the power for the Green Left Turn Indicator light in the dash. Connect this wire to the Left Turn Signal circuit.

REVERSE CIRCUIT: This circuit has two wires that are used to power the backup lights. Connect one of the two wires to the fuse block to provide +12V to the Reverse Circuit. Connect the other wire to the backup lights in the rear of the car. These two wires are connected through the engine harness to the backup light switch in the transmission.

BRAKE SWITCH: This wire provides a signal to the ECU indicating that the brakes are be applied. Contrary to most Honda conventions, this wire supplies +12V to the ECU from the Brake Light Switch. Connect to the output side of the Brake Light Switch. The output is the side that powers the Brake Lights.

The **MIL light (Malfunction Indicator Light)** is connected to a +12V source and the wire in the harness supplies a ground from the ECU. It will come on if there is a code. To check the codes the **SCS (Service Check Switch)** wire has to be connected to ground (we usually do this with a momentary push button switch).

